

Communications & Power Industries Coaxial Magnetron



FEATURES:

- Frequency 2.7 – 2.9 GHz
- Peak power output 800 kW
- Duty cycle .001
- Anode voltage 33 kV
- Anode current 60 amps
- Pulse width 2.4 microseconds
- Heater 70 volts @ 3.2 amps
- Air cooled
- Mechanically tunable

BENEFITS:

- Long life
- Exceptional frequency stability

APPLICATIONS:

- Air traffic control radars
- Weather radars

CPI S-Band 800 kW Magnetron: VMS1177

Electrical Specifications

Frequency	2.7 – 2.9 GHz
Peak Power Output	800 kW
Average Power Output	880 W
Pulse Voltage	30.0 – 37.0 kV
Peak Anode Current	65 A
Average Anode Current	60 mA
Pulse Width	2.4 μ S
Duty Cycle	0.0011
Maximum Filament Voltage	77 V
Maximum Filament Current	3.5 A
Minimum Warm-Up Time	900 S
Maximum Load VSWR	1.3:1

Mechanical and Environmental Specifications

Cooling	Forced air
Maximum Body Temperature	125°C
Mounting Position	Any
Support	Mounting flange
Coupling	WR 284 mates with UG585A/U choke flange
Weight	95 lbs. (43.09 kg)

With a history of producing high quality products, we can help your with magnetron.

Contact us at BMDMarketing@cpii.com or call us at +1 978-922-6000.

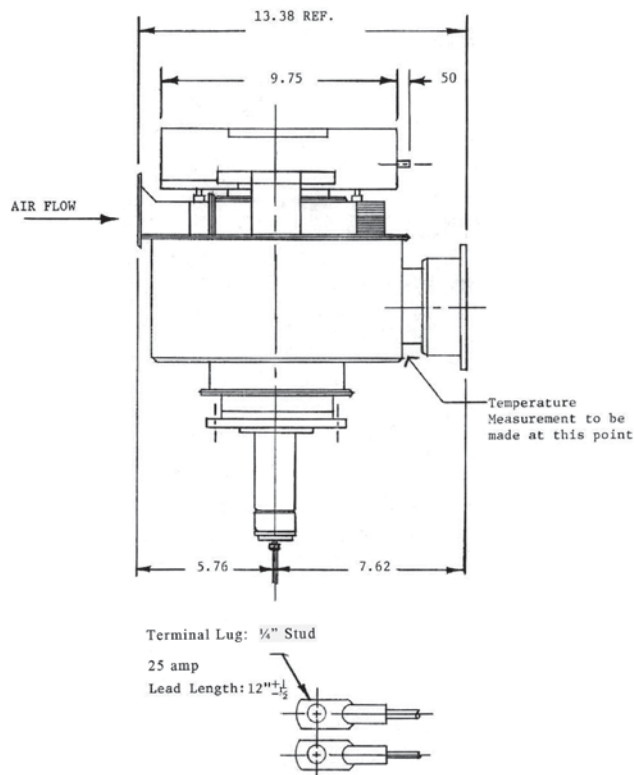
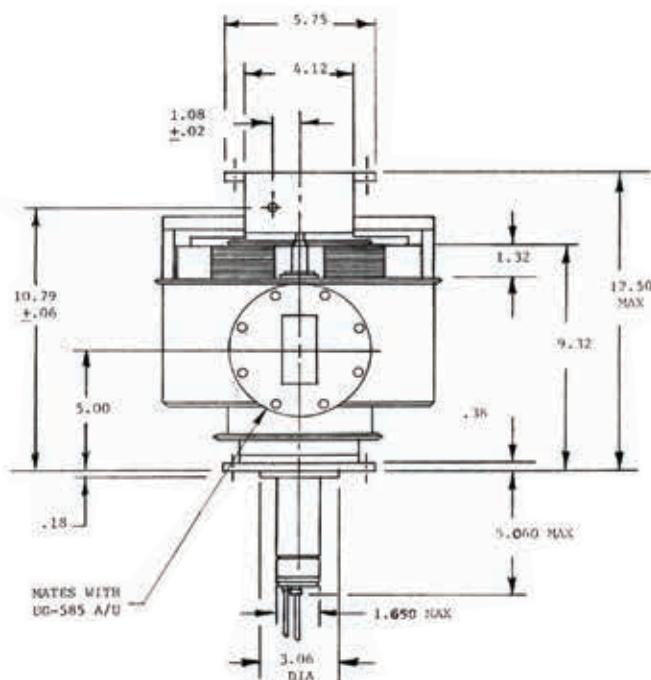

Beverly Microwave Division
150 Sohier Road
Beverly, Massachusetts
USA 01915

tel +1 978-922-6000
email BMDMarketing@cpii.com
fax +1 978-922-8914
web www.cpii.com

For more detailed information, please refer to the corresponding CPI technical description if one has been published, or contact CPI. Specifications may change without notice as a result of additional data or product refinement. Please contact CPI before using this information for system design.

©2020 Communications & Power Industries LLC. Company proprietary; use and reproduction is strictly prohibited without written authorization from CPI.